

Accessories for Vessels



Small Things Make a Big Difference

# LED Navigation Lights

**BÖNING**  
SHIP AUTOMATION

## Dimensions in Full-Scale.

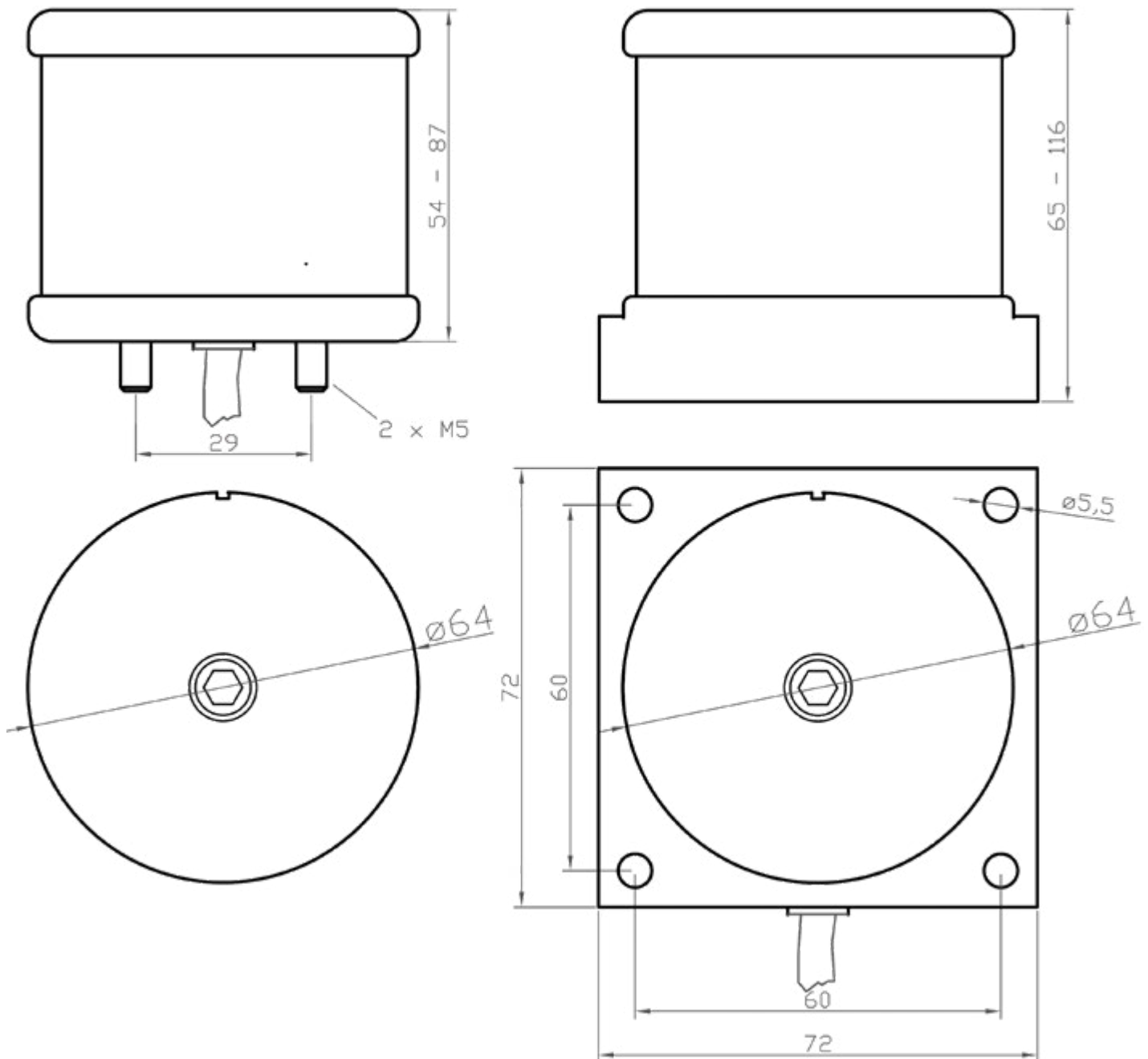

Texts and illustrations in this brochure are non-binding. Changes may be made due to technical improvements.

©2020 Böning Automationstechnologie GmbH & Co. KG

# More Light. Less Energy.

High reliability and compact design of the new navigation lights allow their installation on professional boats over 50 meters. For professional shipping long lifetime and low maintenance costs are essential.

In comparison to traditional techniques available on the market, our newly designed bicolor side lights have remarkable advantages. Thus, energy consumption is reduced from 25 to 1.6 Watts. Furthermore, the lifetime of the new lights is much longer than the one of navigation lights existing on the market.

Very high quality material, such as seawater proof aluminum and stainless steel is used to produce our LED navigation lights. Weather resistant lenses made of boron glass guarantee longterm transparency.

Extensive endurance tests have confirmed functionality and persistence of the LED navigation lights also under adverse seawater conditions. Due to high performance LED, our navigation lights develop nautical reach of over two or three nautical miles, the masthead light even over five or six nautical miles respectively.

## Classification

The Böning LED navigation lights are certified and approved in accordance to the EU regulations.



## APEX Certification

Böning LED navigation lights are now also available as an explosion protected version for zones 2 and 22.



**Our LED navigation lights combine excellent technical characteristics with noble design. They are available in three versions:**



### Standard

Seawater resistant aluminum with hard Elox coating, much harder and seawater resistant than the traditional one



### Classical

Polished brass housing for fans of beautiful classical design and traditional materials



### Base

Version with a square base for direct installation on horizontal surfaces

Double lanterns for vessels over 50 meters are also available.

# Lights for Vessels up to 50 m.



Type		Weight (g)	Power Consumption (W)	Visibility (NM)	Diameter/height (mm) +	Voltage (V DC)
<b>Red port 112.5°</b>		330	1.0	2	64/54	12/24
<b>Green starboard 112.5°</b>		330	1.2	2	64/54	12/24
<b>White stern 135°</b>		330	1.0	2	64/54	12/24
<b>Yellow towing stern 135°</b>		330	1.3	2	64/54	12/24
<b>Red stern 135°</b>		330	1.0	2	64/54	12/24
<b>White masthead 3 NM 225°</b>		350	1.8	3	64/54	12/24
<b>White masthead 5 NM 225°</b>		370	5.0	5	64/54	24
<b>White all-around 360°</b>		300	1.5	2	64/54	12/24
<b>Red all-around 360°</b>		300	1.9	2	64/54	12/24
<b>Green all-around 360°</b>		300	1.8	2	64/54	12/24
<b>Yellow all-around 360°</b>		300	1.9	2	64/54	12/24
<b>White signal 180°</b>		350	2.4	2	64/54	12/24
<b>Red signal 180°</b>		350	2.8	2	64/54	12/24
<b>Green signal 180°</b>		350	2.9	2	64/54	12/24
<b>Yellow signal 180°</b>		350	1.6	2	64/54	12/24
<b>Bicolor* 112.5°/112.5°</b>		330	1.6	2	64/54	12/24
<b>Tricolor*</b>		330	2.4	2	64/54	12/24
<b>Tricolor/Anchor*</b>		350	1.5/2.4	2	64/54	12/24

\* max. vessel length 20 m

+ base version is 11 mm higher and 170 g heavier.

# Lights and Double Lights for Vessels over 50 m.



Type		Weight (g)	Power Consumption (W)	Visibility (NM)	Diameter/Height (mm) +	Voltage (V DC)
<b>Red port 112.5°</b>		330	1.9	3	64/54	12/24
<b>Green starboard 112.5°</b>		330	2.0	3	64/54	12/24
<b>White stern 135°</b>		330	1.7	3	64/54	12/24
<b>Yellow towing stern 135°</b>		330	2.1	3	64/54	12/24
<b>Red stern 135°</b>		330	1.9	3	64/54	12/24
<b>White masthead 6 NM 225°</b>		510	9.8	6	64/54	24
<b>White all-around 360°</b>		300	2.9	3	64/54	24
<b>Red all-around 360°</b>		300	3.3	3	64/54	24
<b>Green all-around 360°</b>		300	3.2	3	64/54	24
<b>Yellow all-around 360°</b>		300	3.4	3	64/54	24
<b>White signal 180°</b>		380	2.4	3	64/54	24
<b>Red signal 180°</b>		380	2.8	3	64/54	24
<b>Green signal 180°</b>		380	2.8	3	64/54	24
<b>Yellow signal 180°</b>		380	2.9	3	64/54	24
<b>White anchor manoeuvre 360° #</b>		300	4.5	5	64/54	24
<b>White all-around flash 360° #</b>		300	2.9	3	64/54	24

# not available as double light

+ base version is 11 mm higher and 170 g heavier.

# Accessories for LED Lights.



**Lamp holder bow/stern**



**Lamp holder starboard side**



**Lamp holder port side**



**Lamp holder mast**



**Lamp holder top**



**Lamp holder mast-combi**



**LED spotlight matching  
lamp holder mast-combi**

10° beam angle  
22° beam angle  
40° beam angle



**Mast-combi protection**



**Holder wind indicator**

# Adapter Plates for LED Lights.

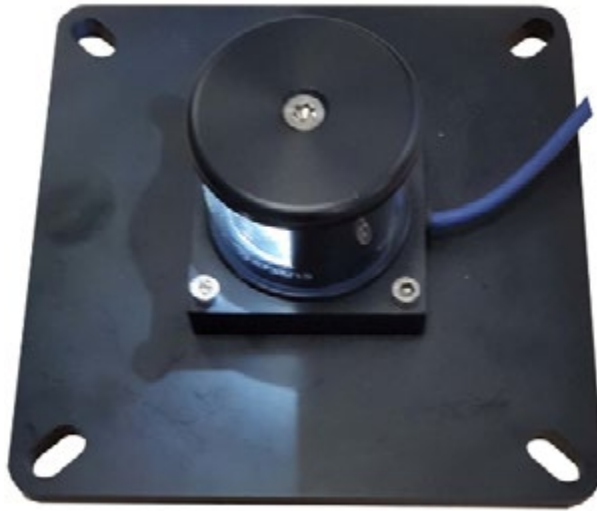

**AHD-SQA adapter plate for old bulb bases**

Now you can replace your navigation lights with the pitch of 145 to 156 mm without tags.



Top view

**AHD-RB round adapter plate**



Bottom view



Top view

**AHD-SQB square adapter plate**



Bottom view



## Monitoring and Control Systems for Navigation Lights

The modular AHD-DPS 02 controls and monitors up to 42 navigation and signal lanterns on board vessels. Due to its modular structure, the system can be matched to customer specific requirements. It is comprised of one basic module and up to 4 extension modules as well as a customer specific operation panel. The system is available in different versions for all customary voltages on board vessels, and it can be used with conventional or LED lanterns.

The minimum configuration encompasses a basic module for 14 lanterns and a standard operation panel. By using additional basic modules, any number of lanterns can be controlled and monitored.

The lanterns are controlled with an operation panel, which provides one operation button and one LED status light for each lamp circuit. Depending on the requirements, the operation panels can be delivered in their standard size or according to the customer's wishes. Additional operation options for touch screen or panel PC are also available.

The lamp current is provided either by the main feed or a second, separate feed (emergency feed). If one of these power feeds fails, it can be manually switched over to the other. Both currents are continuously monitored.

The internal electronics are automatically supplied by one of the available power sources. If one lamp channel is switched off, both switch contacts are disconnected from the power supply with a relay. The lamp outputs are short-circuit proof and maintenance free. The lanterns can be controlled manually during electronics failure.

A collective alarm (closed) contact reports current error conditions to a higher ranking alarm system.

The CAN bus or Modbus enables connection to ancillary systems for convenient control and visualization.



**AHD-DPS 02 G14**

item-no. 13831

## 14 Channel Basic Module for Navigation and Signal Lights Control (24 V LED)

The basic module for controlling and monitoring navigation and signal lamps has been constructed for 14 lamp circuits, which can be controlled and monitored independently; lamp failures, short-circuits, or wire breaks are alerted; in addition, operating time monitoring and end-of-life warning ( $t < 2000$  h) can be parametered for each lamp circuit. The system includes a dual power supply, which switches over to the emergency feed in case of main feed failure. Both feeds are also monitored.

**Additional features:**

- + Direct switching of the lamps is possible even in case of electronics failure
- + All switch channels are short-circuit proof, automatic reset fuses enable maintenance and exchange-free operation
- + The system can be expanded to up to 42 lamp circuits with the extension modules AHD-DPS 02 A07
- + Optional communication modules AHD-DPS 02 GC (RS-422, RS-485, CAN) available on request

Electronics unit for 24 V incandescent lamps (bulbs) in carrier rail housing, suitable for carrier rail mounting (TS32/35).

**Alternate versions for:**

- **24 V incandescent bulbs** (item-no. 13828)
- **230 V incandescent bulbs** (item-no. 14678)
- **230 V LED lamps** (item-no. 14679)
- **115 V incandescent bulbs** (item-no. 13830)
- **115 V LED lamps** (item-no. 15113)

**AHD-DPS 02 G14**

Inputs	1 x optocoupler input (Alarm acknowledgment)
Outputs	14 x relay output (2 poles, for lamps) 3 x relay contact status signals (Common alarm, supply error, lamp error)
Combined inputs / outputs	1 x connection for operation unit (ribbon cable), 1 x connection for max. 4 extension modules (ribbon cable)
Interfaces	1 x CAN (galvanically isolated), optional communication module AHD-DPS 02 GC for RS-232, RS-485 or CAN
Power supply	24 V DC (+30% / -25%)
Current consumption	420 mA @ 24 V DC
Dimensions (W x H x D)	324 mm x 126 mm x 76 mm
Degree of Protection	IP 20
Weight	approx. 1.05 kg
Operation temperature	-30 °C ... +70 °C
Storage temperature	-50 °C ... +85 °C
Approvals	DNV GL, LR, RMRS, CRS, BV

**AHD-DPS 02 A07**

item-no. 12157

## 7 Channel Extension Module (24 V LED)

Extension module for 7 lamp circuits to expand an existing basic module for monitoring and controlling navigation and signal lamps. Every system can be expanded with up to 4 extension modules to a maximum of 42 lamp circuits.

Alternate versions available for several lamps and voltages



## AHD-DPS 02 B14

item-no. 11414

### Control Panel for Navigation and Signal Light Systems

Operating panel for navigation and signal lamp monitoring AHD-DPS 02 G14 for controlling 14 lamp circuits.

- + Compact design for installation in consoles, panels, and switch control boxes
- + Individual ON/OFF operating keys for 14 navigation and signal lamps
- + Integrated signal LEDs for displaying lamp status, lamp fault, supply fault, and system failure
- + Additional warning indicator for the lamps' rest-of-life (2,000 hours remaining)
  
- + All signal LEDs are automatically dimmed
- + Integrated alarm buzzer and acknowledge key with lamp test function
- + Optional switch for releasing an existing remote control (via Basic Module AHD-DPS 02 G14's CAN port)



## AHD-DPS 02 BS

### Customer Specific Control Panel

For controlling our navigation and signal lamp monitoring system AHD-DPS 02 G14.

Identical technical qualities and options as standard operating panel (see AHD-DPS 02 B14, item-no. 11414 or variant). Lamp control elements and labels are arranged individually, according to tabular or graphic templates.

Depending on the application and number of lamp channels to be controlled, various sizes are available.

Device for console installation or flush mounting.

#### Alternate versions:

- **AHD-DPS 02 B21** with 21 channels (item-no. 11481)
- **AHD-DPS 02 B28** with 28 channels (item-no. 12521)
- **AHD-DPS 02 B35** with 35 channels (item-no. 12522)
- **AHD-DPS 02 B42** with 42 channels (item-no. 12382)

#### AHD-DPS 02 B14

Combined inputs / outputs	1 x connection to basic module (ribbon cable)
Power supply	24 V DC (+30% / -25%)
Current consumption	400 mA @ 24 V DC
Dimensions (W x H x D)	150 mm x 150 mm x 80 mm
Degree of Protection	IP 22 (front side with protection cover IP 54)
Weight	approx. 0.5 kg
Operation temperature	-30 °C ... +70 °C
Storage temperature	-50 °C ... +85 °C
Approvals	DNV GL, LR, RMRS, CRS, BV

Device for installation in consoles or switch boards.

#### Versions:

- **with front frame 150 mm x 150 mm** (item-no. 10945)
- **with front frame 294 mm x 150 mm** (item-no. 11061)

#### AHD-DPS 02 BS

Outputs	1 x connection to basic module, up to 4 connections to extension modules
Power supply	24 V DC (+30% / -25%)
Current consumption	400/600/800 mA @ 24 V DC
Dimensions (W x H x D)	150/294 mm x 150 mm x 80 mm
Degree of Protection	IP 22 (front side with protection cover IP 54)
Weight	approx. 0.5 kg / 0.7 kg / 0.9 kg
Operation temperature	-30 °C ... +70 °C
Storage temperature	-50 °C ... +85 °C
Approvals	DNV GL, LR, RMRS, CRS, BV

# AHD-DPS02 System for 24VDC with 4 extension modules and PC alarm system

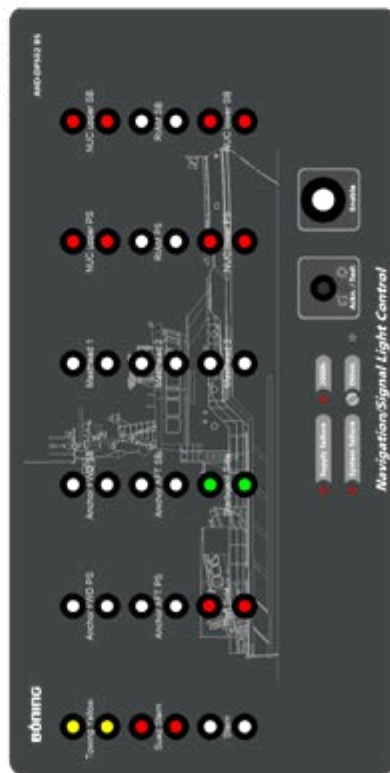
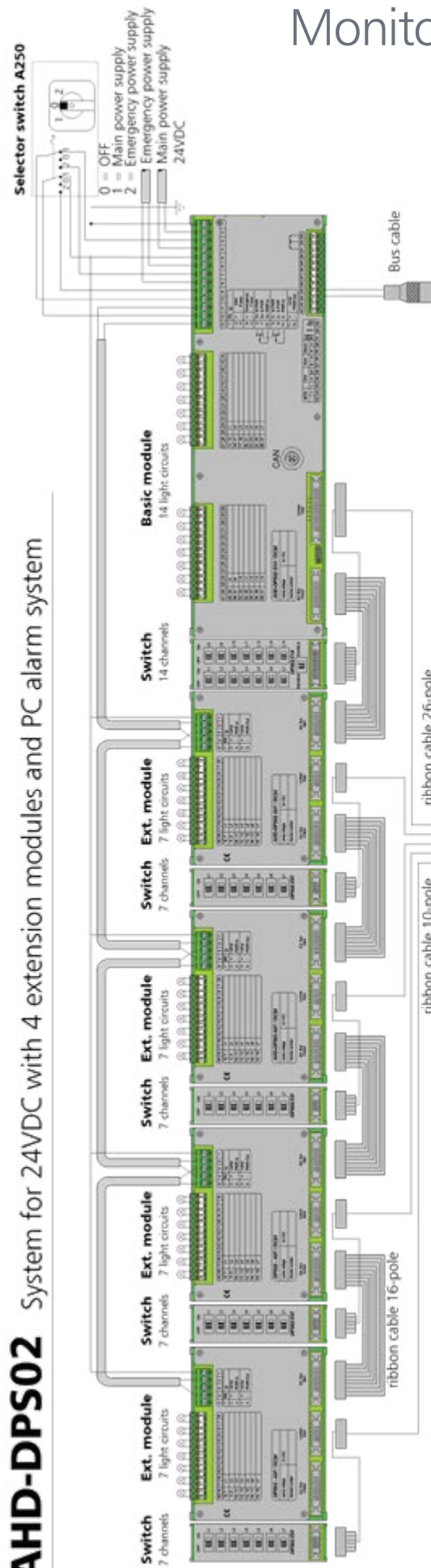

## Control panel

Control panel/switch for lights control during system failure (required by classification society)



## 15" Touchscreen display AHD 1215 (flush-mounted) or standard PC from alarm system

Control and monitoring via Modbus RS485 or CAN bus

[www.boening.com](http://www.boening.com)



- **Headquarters in Ganderkese, Germany**
  - Branches in the U.S.A., Brazil, Italy, Spain, and Croatia
  - **Sales and Service Partners**
- For a list of our partners, please visit our website [www.boening.com](http://www.boening.com)



**Böning Automationstechnologie  
GmbH & Co. KG**

Am Steenöver 4  
27777 Ganderkese  
Germany

Phone: +49 4221 9475 0  
Fax: +49 4221 9475 222  
Email: [info@boening.com](mailto:info@boening.com)